



# INSTALLATION INSTRUCTIONS & MAINTENANCE GUIDE

## FACTORY-BUILT 650° C INSULATED CHIMNEY



Tested To  
**CAN/ULC-S629**  
&  
**UL103 Type HT**



**A MAJOR CAUSE OF CHIMNEY-RELATED FIRES IS FAILURE TO MAINTAIN REQUIRED CLEARANCES (AIR SPACES) TO COMBUSTIBLE MATERIALS.**

**IT IS OF THE UTMOST IMPORTANCE THAT THIS CHIMNEY BE INSTALLED ONLY IN ACCORDANCE WITH THESE INSTRUCTIONS.**

**PLEASE READ ALL INSTRUCTIONS BEFORE BEGINNING YOUR INSTALLATION. FAILURE TO INSTALL THIS SYSTEM IN ACCORDANCE WITH THESE INSTRUCTIONS WILL VOID THE CONDITIONS OF CERTIFICATION AND THE MANUFACTURERS WARRANTY. KEEP THESE INSTRUCTIONS IN A SAFE PLACE FOR FUTURE REFERENCE.**



Selkirk Corporation  
5030 Corporate Exchange Blvd.  
Grand Rapids, MI 49512  
Toll Free: 1.800.433.6341

**SELKIRK®**  
www.selkirkcorp.com  
info@selkirkcorp.com

Selkirk Canada Corporation  
P.O. Box 526, Depot 1  
Hamilton, ON L8L 7X6  
Toll Free: 1.888.SELKIRK (735.5475)

# TABLE OF CONTENTS

---

TYPES OF APPLIANCES	3
PRE-INSTALLATION GUIDELINES	3
TOOLS	3
FRAMING DETAILS	4
DECORATOR CEILING SUPPORT	4
STOVE PIPE ADAPTER	4, 5
ATTIC INSULATION SHIELD	5
ELBOW INSTALLATION	6
WALL SUPPORT	6, 9
CATHEDRAL CEILING SUPPORT	9, 10
ROOF SUPPORT	10
RAFTER RADIATION SHIELD	10
ROOF FLASHING	11
UNIVERSAL ROOF GUY KIT	12, 13
MASONRY ADAPTER KIT	13, 14
ADAPTER PLATE	14
MAINTENANCE AND CLEANING OF CHIMNEY	14, 15
REPLACEMENT PARTS LIST	15
CHART 1 - OFFSET CHIMNEY INSTALLATION	16
CHART 2 - CHIMNEY HEIGHT ABOVE THE ROOF	17
CHART 3 - CONNECTOR PIPE CLEARANCES - CATHEDRAL SUPPORT	17
INSTALLATION RECORD & PRODUCT REGISTRATION	18

If you have a basic knowledge of carpentry and how to use hand tools, taking on the task of installing your new venting system will be easy. However, it is important that these installation instructions are followed. If you choose to have your product professionally installed, we recommend these products be installed by professionals who are certified in Canada by WETT (Wood Energy Technology Transfer) or l'APC (l'Association des professionnels du chauffage).

## TYPES OF APPLIANCES

Your model JM/ALTchimney is intended for venting gas, liquid, or solid fuel fired residential type appliances and building heating appliances. It has been tested and approved to withstand temperatures of up to 2100°F (1150°C) for three thirty minute intervals. Continuous operating temperatures should not exceed 1200°F (650°C).

## PRE-INSTALLATION GUIDELINES

Your model JM/ALT chimney and connecting stove pipe diameter should be sized in accordance with the appliance manufacturer's recommendations.

Plan the installation of your appliance and chimney in such a way that both your chimney and your stove pipe run is as short and straight as possible. By having too long and / or multiple bend installations you can reduce system draft which can affect the operation, and / or performance of your appliance and / or chimney system. The chimney should be located within the building so as to avoid cutting or altering load bearing members such as joists, rafters, studs, etc. If you require to cut or alter an existing load bearing member, special reframing methods are required which often include doubling of adjacent members. If such a case arises, contact your local Building Code Official regarding local regulations and proper installation methods.

Sections of the JM/ALT chimney which pass through accessible areas of the building such as through closets, storage areas, occupied spaces or anyplace where the surface of the chimney could be contacted by persons or combustible materials **must** be enclosed in a chase to avoid personal contact and damage to the chimney. The chase may be fabricated using standard building materials. Drywall mounted on 2" x 4" studs is typically used in this situation.

**MAINTAIN A 2" (50MM) MINIMUM AIR SPACE CLEARANCE BETWEEN INSULATED CHIMNEY SECTIONS AND COMBUSTIBLE MATERIALS.**

**WARNING: DO NOT PLACE ANY INSULATING MATERIALS OR RUN ANY ELECTRICAL WIRING WITHIN THE REQUIRED AIR CLEARANCE SPACE SURROUNDING THE CHIMNEY.**

Before commencing the installation ensure that you obtain any necessary building permits, and that your installation will conform with all federal and municipal building codes requirement.

**CONTACT LOCAL BUILDING OR FIRE OFFICIALS ABOUT RESTRICTIONS AND INSTALLATION INSPECTION IN YOUR AREA.**

Except for installation in one and two family dwellings, a factory-built chimney that extends through any zone above that on which the connected appliance is located is to be provided with an enclosure having a fire resistance rating equal or greater than that of the floor or roof assemblies through which they pass. The space between the outer wall of the chimney and the enclosure shall be at least 2" (50mm).

Be sure that ladders are in good condition and always rest on a level firm surface.

Be sure that electrically powered tools are properly grounded.

**WEAR SAFETY GLOVES WHEN HANDLING SHEET METAL PARTS WITH SHARP EDGES**

Authorities require that the chimney extend not less than 3 ft (900 mm) above the highest point where it passes through the roof of a building and not less than 2 ft (600 mm) above any portion of the building within 10 ft (3m). See Figure 1 and Chart 2 on page 14 of these instructions.

**FIGURE 1**

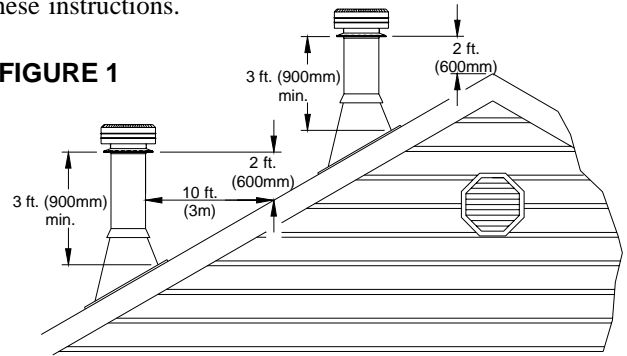

The use of Locking Bands at all chimney joints is recommended for added safety and stability when exposed to high winds and as a precaution against accidental unlocking of lengths when the system is inspected and swept.

The ideal location for your chimney system is within the building envelope. In cold climates, the use of external chimney may result in operational problems such as poor draft, excessive condensation of combustion products and rapid accumulation of creosote. Under these circumstances, the installation of the chimney within the building is strongly recommended.

If the chimney must be installed on an exterior wall it is recommended that the chimney be enclosed below the roof line to protect the chimney from cold outdoor temperatures, this may help reduce condensation, creosote formation and enhance draft. Provide an access door by the Tee Plug for chimney inspection and cleaning. The exterior enclosure may be insulated, maintaining the required minimum air space clearance of 2" (50mm) to any part of the chimney. Consult local building codes for cold climate application.

Do not install the chimney directly at the outlet of the appliance. Interconnecting stove pipe is required unless the appliance is specifically approved for that type of installation.

Use only with an appliance listed by a recognized testing authority such as CSA, Underwriters Laboratories Inc., Underwriters Laboratories of Canada or Intertek Testing Services/Warnock Hersey.

The flue diameter of gas or oil fired appliances should comply with the appropriate Installation Codes such as CAN/CSA-B139.00 or CAN/CSA-B149.1-00 when installed in Canada, and the Installation Codes NFPA 54, ANSI Z223.1 and NFPA 31 in the United States.

**YOUR CHIMNEY HAS BEEN TESTED, AND LISTED USING ALL OF THE SUPPORTS, SHIELDS, ETC., DESCRIBED HEREIN. DELETION OR MODIFICATION OF ANY OF THE REQUIRED PARTS OR MATERIALS MAY SERIOUSLY IMPAIR THE SAFETY OF YOUR INSTALLATION, AND VOID THE CERTIFICATION AND OR WARRANTY OF THIS CHIMNEY**

## TOOLS

Your model JM/ALT chimney system is designed for installation using standard building materials and procedures. The following tools/equipment may be required as well as some others depending on the location and structure in which the chimney is to be installed:

- Safety gloves
- Safety goggles
- Hammer and nails
- Tin snips
- Tape measure
- Screwdrivers and pliers
- Plumb line and level
- Square
- Keyhole saw or power jig saw
- Caulking gun

## FRAMING DETAILS

Plan your installation carefully. If possible, position the stove so that the flue outlet is centered between joists or rafters. Drop a plumb line to the center of the flue outlet and mark this center point on the ceiling. Lay out and frame in all openings ensuring the specified 2" (50 mm) clearance to combustibles is maintained. Refer to Table 1 and applicable Tables for framing dimensions and mark the appropriate cutting lines around the center point. All openings should be square, plumb and in perfect alignment with each other (see figure 2).

For sloping roofs (cathedral/vaulted ceiling), ensure that the framing dimension is measured in the horizontal plane (see figure 3).

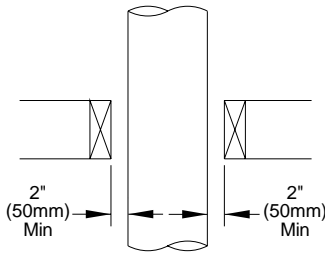

**FIGURE 2**  
Typical Joist Framing

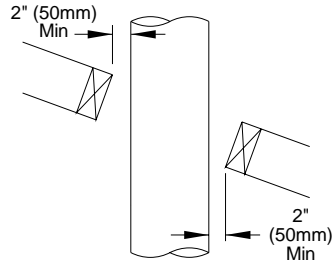

**FIGURE 3**  
Typical Roof Joist Framing

TABLE 1		Framing Dimensions Table		
Chimney Flue Diameter		*Decorator Ceiling Support	*Wall (Support) Thimble	All Other Framing
6" (150mm)	in.	14 <sup>3</sup> / <sub>8</sub> x 14 <sup>3</sup> / <sub>8</sub>	14 <sup>3</sup> / <sub>8</sub> x 14 <sup>3</sup> / <sub>8</sub>	14 x 14
	mm	365 x 365	365 x 365	355 x 355
7" (175mm)	in.	14 <sup>3</sup> / <sub>8</sub> x 14 <sup>3</sup> / <sub>8</sub>	14 <sup>3</sup> / <sub>8</sub> x 14 <sup>3</sup> / <sub>8</sub>	15 x 15
	mm	365 x 365	365 x 365	380 x 380
8" (200mm)	in.	14 <sup>3</sup> / <sub>8</sub> x 14 <sup>3</sup> / <sub>8</sub>	14 <sup>3</sup> / <sub>8</sub> x 14 <sup>3</sup> / <sub>8</sub>	16 x 16
	mm	365 x 365	365 x 365	405 x 405

\* The clearance to combustibles obtained with a correctly installed Decorator Ceiling Support or Wall Thimble in the framed opening specified has been tested. **The 2" clearance does not apply at these locations.** When cutting the inside "finished" surface of your wall or ceiling cut a "round hole" to the framing dimension in Table 1.

## INSTALLATION PROCEDURES

### DECORATOR CEILING SUPPORT

To complete a proper Decorator Ceiling Support installation, the following parts may be required:

- Decorator Ceiling Support (DCS): Required when supporting a chimney through a flat level ceiling.
- Stove Pipe Adaptor (ASE): Transition from the chimney to flue pipe.
- Attic Insulation Shield (AIS): Required where a chimney passes from a lower living space into an upper living or an attic space.
- Universal Shielding Insulation (JUSI): To stop cold air infiltration into the dwelling when installed in conjunction with the Attic Insulation Shield.
- Rafter Radiation Shield (RRS): Required when the chimney is enclosed immediately below the roof.
- Roof Flashing Assembly (Including Storm Collar): Required when the chimney penetrates a roof.

- Suitable Lengths of Chimney : The chimney diameter should be sized to suit the appliance.

- 15° or 30° Chimney Elbow Kit: To avoid cutting of joists and clear other obstructions. Kit includes: 2 Elbows, 1 Offset Support and 4 Locking Bands.

- Rain Cap: To prevent rain and/or debris from entering in the chimney. Standard or Deluxe model.

The Decorator Ceiling Support will support up to 40 ft. (13 m) of chimney sections, all of which must be installed above the support. Figures 5 & 6 show the 2 most common types of Decorator Ceiling Support Installation. Frame (on all 4 sides) a level square opening with the inside dimensions of 14-3/8" (365mm) square. Remember to cut a round hole on the finishing (gyprock) side.

Slide the Trim Ring (Finishing Plate) onto the Decorator Ceiling Support and position the assembly into the framed opening from below. Ensure that the Finishing Plate is flush with the underside of the ceiling and the assembly is level and plumb. Secure in place with 3 x 6d (2") nails or #8 x 1-1/2" wood screws through each of the 4 straps.

### STOVE PIPE ADAPTER

The Stove Pipe Adapter (ASE) is installed by twist-locking it into the bottom end (female end) of the first Chimney Section that enters the Ceiling Support. Do not install an elbow in the Ceiling Support. Make sure that the male coupler of the insulated Chimney Length is pointing upwards as indicated by the arrow on the chimney label. Lower the assembly down into the Decorator Ceiling Support ensuring that the Stove Pipe Adapter sleeve is protruding through the support and into the living space (see Figure 4).

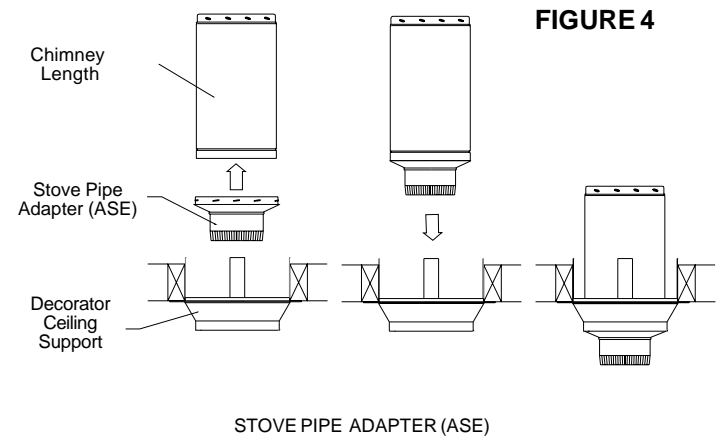

The crimped end (stub) of the Stove Pipe Adapter is intended to fit inside of the flue pipe from a solid fuel appliance, thus preventing condensate drips at the chimney connection.

Install inter-connecting flue pipe following the appliance manufacturer's installation instructions and appropriate building code requirements and the Installation Code B-365, keeping in mind that the flue pipe run should be as short and straight as practicable. Generally, for a wood burning appliance installation, an 18" minimum clearance to combustibles must be maintained for a single wall flue pipe. The exception to this is a double wall stove pipe, such as Selkirk's **Model DSP** which can be installed at reduced clearances to combustibles. See separate installation instructions for more details.

Install additional chimney sections and lock together by turning clockwise until the two sections lock together snugly. Install a Locking Band to secure the two chimney sections. Continue adding chimney lengths until a height of about 2 ft. below the next ceiling level is achieved.

**NOTE:** The Decorator Ceiling Support cannot be used when the chimney terminates in a room with a suspended ceiling. When false ceiling are encountered, use a Cathedral Ceiling Support to extend into the room below the finished ceiling.

When installing the Attic Insulation Shield above the Decorator Ceiling Support as shown in Figure 5, be certain that the base of the shield is flush with the top of the joist framing and nail in place using 1" spiral nails or #8 x 1" wood screws.

**NOTE:** To reduce cold air infiltration into the dwelling you can install the optional Universal Shielding Insulation (JUSI) into the Attic Insulation Shield. See separate installation instructions packaged with the JUSI.

When installing the Attic Insulation Shield where the chimney passes from a living space to an enclosed attic space, as shown in figure 6, or between floors, install the shield from below and nail in place using 1" spiral nails or #8 x 1" wood screws. A Rafter Radiation Shield is required at the roof level when the chimney is enclosed below the roof line.

**NOTE:** Do not seal the gap around the chimney where it passes through the Attic Insulation Shield in an attempt to stop cold air infiltration. The use of the Universal Shielding Insulation (JUSI) is recommended. An accoustical sealant may be applied to the outer perimeter of the AIS bottom plate where it contacts the finished ceiling side as per Figure 6 or the top of the ceiling joist when installed from above as per Figure 5. When installed from below, a Finishing Plate can be installed below the AIS and an accoustical sealant applied to the outer perimeter of the bottom plate in conjunction with the JUSI.

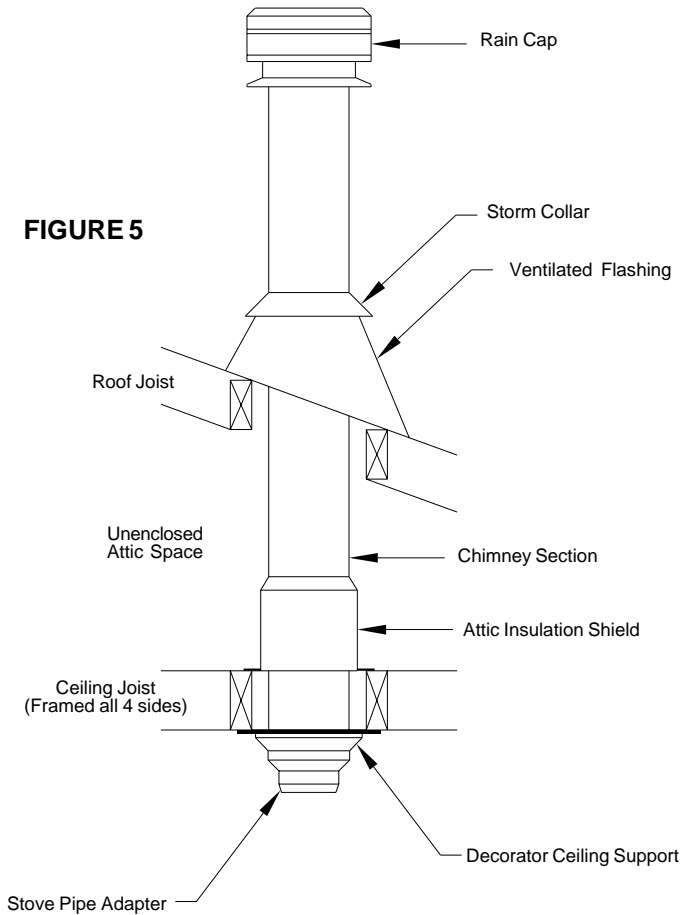

**Single Story Installation**

## ATTIC INSULATION SHIELD

An Attic Insulation Shield must be installed where a chimney passes from a lower living space into an upper living space or into an attic space. It is designed to keep insulation materials from coming into contact with the chimney and will protect up to a 10" (250 mm) thickness of insulation. Where height restrictions will not permit the use of the Attic Insulation Shield, an enclosure from the attic joist to the roof joist will be sufficient. All chimney enclosures must maintain the required minimum air space clearance of 2" (50mm) to the chimney. When enclosing the chimney below the roof line, a Rafter Radiation Shield (RRS) must be installed at the roof level (see Figures 6 and 21).

For a proper installation, the opening must be fully framed at 2 inches of clearance to the outside casing of the chimney with framing material of the same dimension as the ceiling or floor joist as per the Framing Dimensions in Table 1.

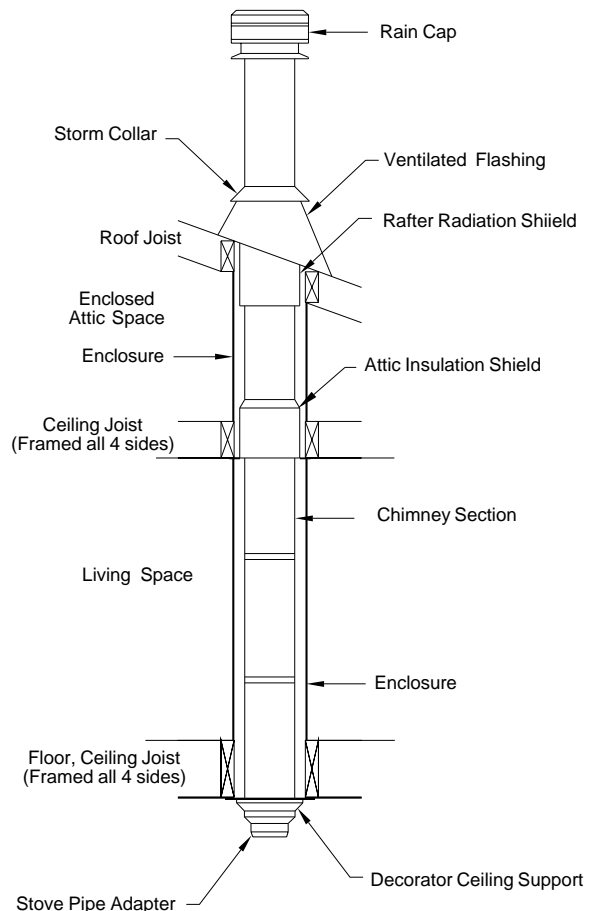

**FIGURE 6 Two Story Installation (Enclosed Attic)**

## ELBOW INSTALLATION

One pair of (two) 15° or 30° elbows may be used in an interior installation to provide an offset in order to avoid cutting of joists and to clear other obstructions. The maximum permissible angle with solid fuel installation is 30 degrees. The vertical run of chimney above an offset must be supported with an elbow support. Each elbow support will support 15 ft. (4.5 m) of chimney and the maximum length of chimney allowed between the elbows is 6' (2m). Refer to the Offset Chart 1 on page 13 in these instructions for more details. Elbow kits contains 2 Elbows, 4 Locking Bands and an Elbow Support.

The female end of the Elbows are **not** embossed, this ensures proper alignment of the chimney system is maintained. Locking Bands must be installed at all chimney joints forming an offset.

Install the insulated offset Elbow on the vertical chimney length and position the Elbow in the required direction. Fasten the Elbow to the chimney Length with the supplied Locking Band.

Place the required offset chimney Length(s) as per the Offset Chart 1 (page 16) for appropriate length(s). Turn it clockwise to lock it in place and secure with the supplied Locking Band.

Install the remaining offset Elbow to turn the chimney back to the vertical position and fasten in place with the supplied Locking Band.

During installation provide supplementary support for the offset section to avoid undue stress on connected elbows.

Install an Elbow Support on the Length just above the highest Elbow. Attach the Support Band to the chimney with 4 nuts and bolts, and then install four stainless steel sheet metal screws through the pre-punched holes. Attach the Support Straps to the Support Band assembly and nail the Support Straps to the framing using 6d (2") nails or #8 x 1-1/2" wood screws (see Figure 7).

**Never install an elbow in a joist area. Chimney lengths must pass vertically through framed joist areas.**

FIGURE 7

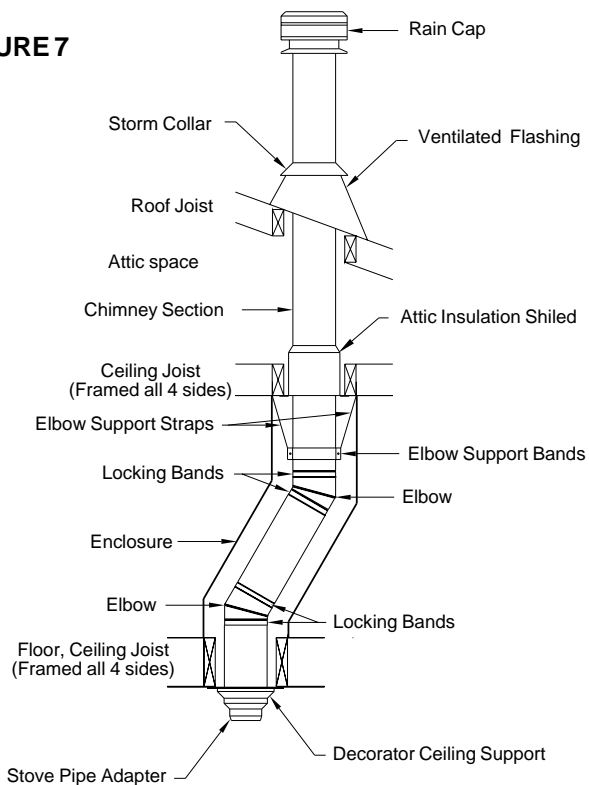

Offset (Elbow) Installation

## WALL SUPPORT

As previously mentioned, the ideal location for your chimney system is within the building envelope. A Wall Support installation is required when the above mentioned location is not possible.

To complete a proper Wall Support installation, the following parts will or may be required:

- Wall Support (WS): Intended for a through-the-wall installation where the chimney has a horizontal connection.
- Stove Pipe Adaptor (ASE): Transition from chimney to flue pipe.
- Insulated Tee (TEE) with Insulated Tee Cap (ITP): Allowing a horizontal connection to the chimney.
- Roof Flashing Assembly: Required when the chimney penetrates a roof or a roof overhang.
- Rafter Radiation Shield (RRS): Required when the chimney is enclosed immediately below the roof.
- Wall Band (WB): Required to provide lateral support to chimney.
- Suitable Lengths of Chimney: The chimney diameter should be sized to suit the appliance.
- Chimney Length: Appropriate length for connection to Tee branch.
- Wall Thimble (WT): Required to pass through a combustible wall.
- Rain Cap: Standard or Deluxe model

**NOTE: NEVER OFFSET AN EXTERIOR CHIMNEY.** The maximum chimney height above a Wall Support is indicated in Table 2 and illustrated in Figure 8, all of which must be above the support.

The Wall Support will allow for an adjustment of 2" to 6" from a vertical wall. Threaded studs are factory installed on both side brackets and the support plate for fast and easy assembly (see Figure 11).

Ensure the Wall Support Brackets are bolted securely to the wall .

FIGURE 8

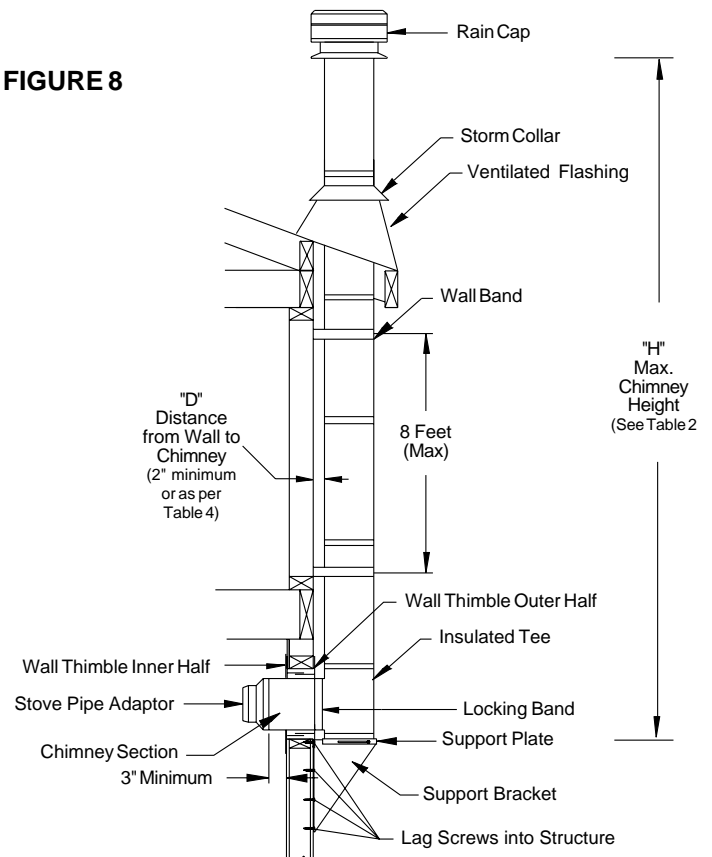

See Table 2 for maximum Chimney Heights based on Chimney Diameter and Distance from Wall

The following steps will assist you in the installation of the Wall Thimble and of the Wall Support. Figure 8 shows a typical Wall Support installation through a combustible wall.

Distance from Wall to Chimney	Table 2 - Wall Support Chimney Height Chart		
	6" ID Chimney	7" ID Chimney	8" ID Chimney
D (inches) Wall/Chimney	H(feet) Max. Height	H (feet) Max. Height	H (feet) Max. Height
2	34	29	26
2.5	33	28.5	25.5
3	32	28	25
3.5	31	27	24
4	30	26	23
4.5	28	24	22
5	26	23	20
5.5	23	21	18
6	21	18	16

D - Distance from wall to the chimney  
H - Height of chimney in feet  
See Figure 8 also.

1. Determine the centre line of the horizontal connection (Chimney Length through the wall) and frame an opening to the dimensions specified for the Wall Thimble in a combustible wall (see Section A in Table 3 and Figure 9-A).

- Use a stud finder to roughly locate the walls studs. Mark the outline of the hole and drill a pilot hole in its center.
- Break out part of the wall covering within the outline to confirm that the hole will be centered between studs and that no electrical wires could be cut by the saw.

2. For a non-combustible wall (concrete block or poured foundation), cut a hole (3/16") greater in diameter than the outside diameter of the chimney as per Table 3.

**NOTE:** When cutting the inside "finished" surface of your wall cut a "round hole" to the framing dimension in Table 3.

3. After framing in your opening to the dimensions specified to the Framing Tables 1 or 3, install the outer half (with the unfinished square plate) of the Wall Thimble into the outside wall opening. Secure in place with appropriate fasteners through the pre-punched holes.

4. Install the inner half (with round plate) of the Wall Thimble into the inside wall opening, ensuring that the shield slides over the shield of the outer half. Once in place and flush against the wall, install the black finishing trim plate onto the wall surface and fasten in place with appropriate fasteners through the 4 pre-punched holes.

**NOTE:** To reduce cold air infiltration into the dwelling you can install the optional Universal Shielding Insulation (JUSI) into the Wall Thimble. See separate installation instructions packaged with the JUSI.

Section	Table 3 - Framing Dimensions Wall Thimble & Support Brackets	Chimney Size (ID)		
		6"	7"	8"
	<b>Minimum Round Hole Diam. For Non-Combustible Wall</b>	10-3/16"	11-3/16"	12-3/16"
A	<b>Wall Thimble Minimum Framed Opening for Combustible Wall</b>	14-3/8"	14-3/8"	14-3/8"
		x	x	x
B	<b>Support Brackets Minimum Framed Opening For Bracing</b>	14-3/8"	14-3/8"	14-3/8"
		11-1/4"	12-1/4"	13-1/4"

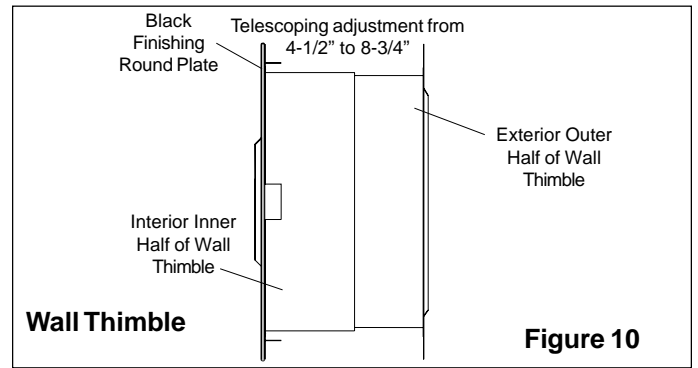

5. Assemble the 2 side Brackets (point of triangle facing down) to the Support Plate (flange up and threaded stud towards the wall) by inserting the threaded studs into the oblong slots (see Figures 11 & 12). Install the supplied nuts on the threaded studs until snug, do not tighten at this time as adjustments may be required. Set aside and prepare the support bracing to secure the side brackets as per the Framing Dimensions in Section B of Table 3 and Figure 9 (B).

Two options are described below for the installation of the Wall Support and the Insulated Tee assembly. Follow Method A if inserting an assembled Insulated Chimney Length and Insulated Tee into the Wall Thimble prior to the Wall Support. Follow Method B if securing of the Wall Support to the wall prior to the Insulated Tee and the Insulated Chimney Length.

**METHOD A**

6. Install an appropriate Insulated Chimney Length such as a one foot section (or longer if required-not to exceed 24 inches) to the horizontal branch of the Insulated Tee. Lock securely into the Tee branch by twisting clockwise. A Locking Band must then be installed to secure the connection. Make sure the nut and bolt are facing down to prevent any water from collecting in the Locking Band. The Tee branch extension must protrude a minimum of 3" into the room.

7. From outside the building, slide the assembly (Chimney Length installed on the Tee Branch) through the Wall Thimble ensuring the male coupling on the Tee is facing upward. The Wall Thimble will provide support until you are ready to install the Wall Support Assembly.

8. Place the assembled Wall Support against the wall (Support Plate Flange up) directly below the Insulated Tee. Slide the Wall Support up to the bottom of the Insulated Tee ensuring that the flange on the top of the Support Plate is inserted into the female coupler.

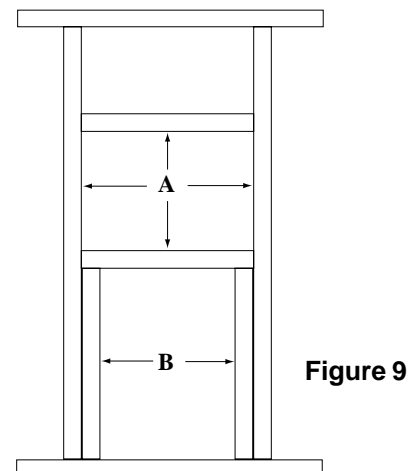

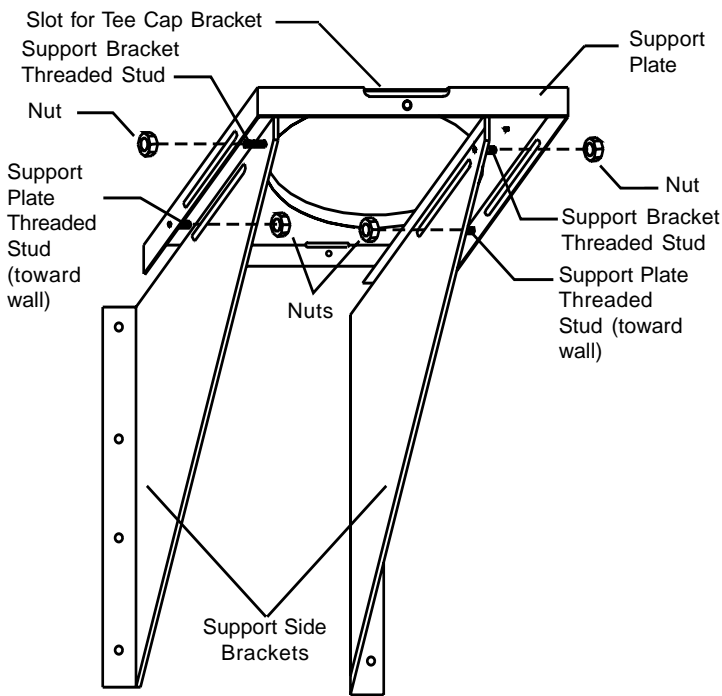
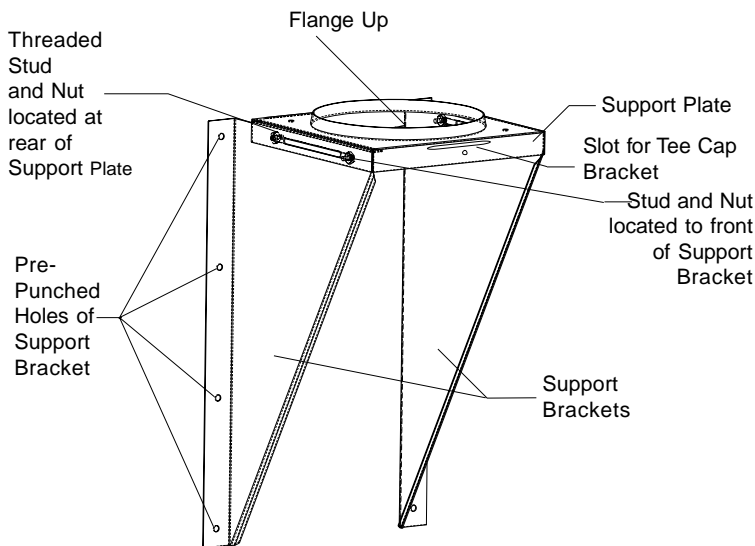

**FIGURE 11**  
**UNDERSIDE VIEW OF THREADED STUDS AND NUTS**

NOTE: THE CHIMNEY LENGTH MUST EXTEND AT LEAST 3" THROUGH THE WALL INTO THE LIVING SPACE WHERE THE STOVE PIPE CONNECTOR WILL BE ATTACHED TO THE CHIMNEY BRANCH.

9. Prior to securing ensure that the Insulated Tee assembly is plumb and level and sitting flush on the Support Plate. Secure to the wall through the pre-punched holes located on each side of the Wall Support Brackets using (8) #14 x 1-1/2" hex head lag screws or #10 x 2" wood screws. Make sure they go into solid bracing as per the requirements in Table 3 Section B and Figure 9 (B), below the prepared Wall Thimble opening. You can drill 5/32" pilot holes. For concrete block or poured foundation use suitable fasteners.

10. Position the Support Plate to the desired distance from the wall as per the limits shown in Table 2 and Figure 8. Tighten the 4 nuts onto the threaded studs. Proceed to Step 14.



**FIGURE 12**  
**FRONT VIEW OF WALL SUPPORT ASSEMBLY**

**METHOD B**

11. Position the Wall Support so that the Insulated Tee will be centered inside the Wall Thimble. Ensure that the Wall Support is level, and secure to the wall through the pre-punched holes located on the sides of each of the support brackets using (8) #14 x 1-1/2" hex head lag screws or #10 x 1-1/2" wood screws. You can drill 5/32" pilot holes for the lag screws. Make sure they go into solid bracing as per the requirements in Table 3 Section B and Figure 9 (B) below the prepared Wall Thimble opening. For concrete block or poured foundation use suitable fasteners.

12. Place the Insulated Tee on the support Plate ensuring that the male coupler of the Tee is facing up and the flange on the top of the Support Plate slides into the female coupler (see Figures 13 & 14).

13. From inside the building, slide an appropriate Insulated Chimney Length such as a one foot section (or longer if required - not to exceed 24 inches) through the Wall Thimble to the horizontal branch of the Insulated Tee. Lock securely into the Tee branch by twisting clockwise. A Locking Band must then be installed to secure the connection. Make sure the nut and bolt are facing down to prevent any water from collecting in the Locking Band. The Tee Branch extension must protrude a minimum of 3" into the room.

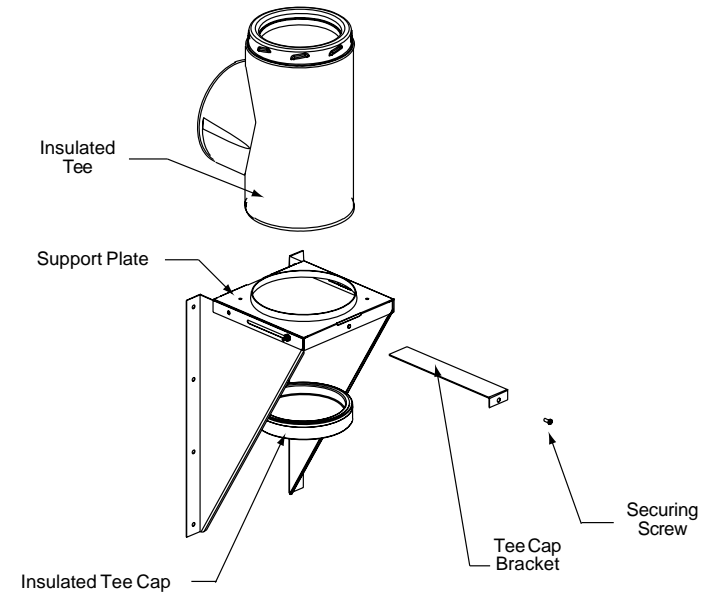

**FIGURE 13 - Explosion View - Wall Support, Insulated Tee and Tee Cap, Tee Cap Bracket and securing Screw.**

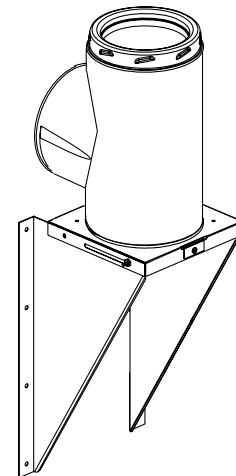

**FIGURE 14 - Assembled Wall Support with Tee Cap Secured in Place**



14. Use a non-hardening high-temperature sealant (500° F) to seal around the horizontal Chimney Length where it enters through the exterior of the Wall Thimble or the concrete wall.

15. Insert the Insulated Tee Cap into the bottom of the Support Plate opening and secure by sliding the Tee Cap Bracket into both slots located at the front and rear of the Support Plate. Make sure the Tee Cap Bracket is beneath the Tee Cap and the other end is exiting through the slot at the back of the Support Plate. Secure in place by threading the securing screw into the nutsert located on the front of the Support Plate (Figures 13, 14 and 15).

NOTE: If ground clearance does not permit the installation of the Wall Support with the Support Bracket facing down, it is permissible to invert these brackets. Inverting the brackets (brackets mounted on the wall above the support plate) can be accomplished by rotating the Support Plate so that the threaded stud faces toward the front and securing each side with (2) #8 x 3/4" bolts (not supplied) through the oblong slots of the support side brackets and the support plate as per Figures 16 and 17. Secure with nuts. In this position, the range of

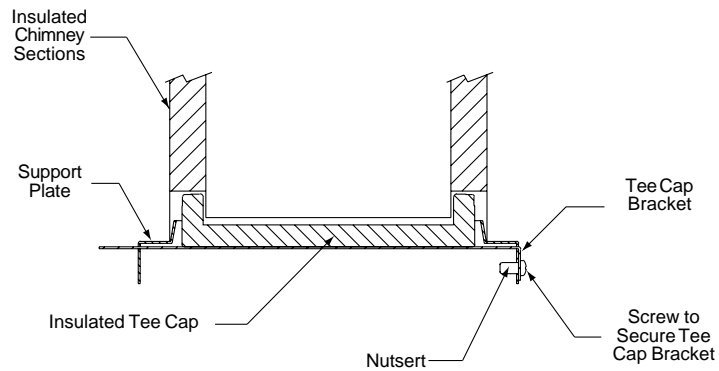

**FIGURE 15 - Securing of Insulated Tee Cap**

**WARNING:** The Insulated Tee Cap must be installed and secured in place. Failure to install could cause fire, injury or death.

adjustability is limited to 5" from the wall (see Table 2). Install the Insulated Tee Cap as per step 15.

16. Chimney Lengths above the Insulated Tee are simply stacked on and locked with a 1/8 clockwise turn.

17. For lateral stability of the chimney above the Wall Support, a Wall Band must be installed along an outside wall. Install the first Wall Band midway up the first Chimney Length above the Insulated Tee and any additional Wall Band to be installed at 8 foot intervals above this point. Secure the Wall Band bracket to the wall using 2 6d (2") spiral nails or #8 x 2" wood screws through the pre-drilled holes (see Figure 18). For concrete or brick veneer walls, use suitable masonry fasteners or other anchoring systems.

18. Fasten securely the Wall Band around the chimney with the supplied nut and bolt. Check for clearances and plumb as you fasten the Wall Bands to the wall. Use a level against the chimney sections at each support stage to keep the assembly plumb.

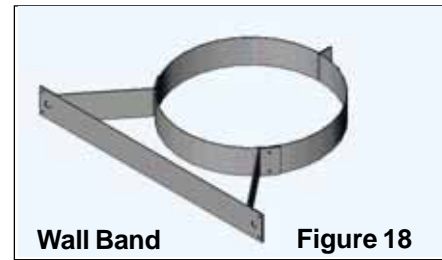

19. If the chimney penetrates an eave or overhang (soffit) cut an opening with 2" clearance all around. To find the exact spot where the chimney will pass through the eaves, drop a plumb line from the underside of the eaves to the outer edge of the leveled chimney. Mark 5 or 6 points to give an outline of the hole. Remember that the hole will need 2" clearance to the chimney surface. Install an Attic Insulation Shield if space permits on the under side of the overhang. If it is not possible, the overhang area can be enclosed and a Rafter Radiation Shield installed at the roof level and a Finishing Plate on the underside of the soffit. If the Attic is open to the overhang, close off the access with suitable building materials ensuring that a 2" air space clearance is maintained. From above, install the Roof Flashing and Storm Collar by following the Roof Flashing section in these instructions. If the overhang is not deep enough to allow the chimney to be fully installed within the overhang, it will be necessary to cut into it. **DO NOT INSTALL AN OFFSET TO CLEAR THE OVERHANG!** Ensure that a 2" air space clearance all around the chimney is respected. Framing and flashing the sides of the opening will be required. Install a Wall Band at this level.

**NOTE:** Interior chimneys installed with a Wall Support must use an Attic Insulation Shield (AIS) in place of Wall Bands if extending through floor/ceiling penetrations and when passing through an unoccupied attic space.

## CATHEDRAL CEILING SUPPORT

To complete a proper Cathedral Ceiling Support installation, the following parts may be required:

- Cathedral Ceiling Support: To support chimney with a sloped ceiling
- Stove Pipe Adaptor (ASE): Transition from the chimney to flue pipe.
- Universal Shielding Insulation (JUSI): To reduce cold air infiltration into the dwelling when installed in conjunction with the Cathedral Ceiling Support.
- Roof Flashing Assembly: Required when the chimney penetrates a roof.
- Suitable length(s) of chimney: The chimney diameter should be sized to suit the appliance.
- Rain Cap: To prevent rain and/or debris from entering into the chimney. Standard or Deluxe model.

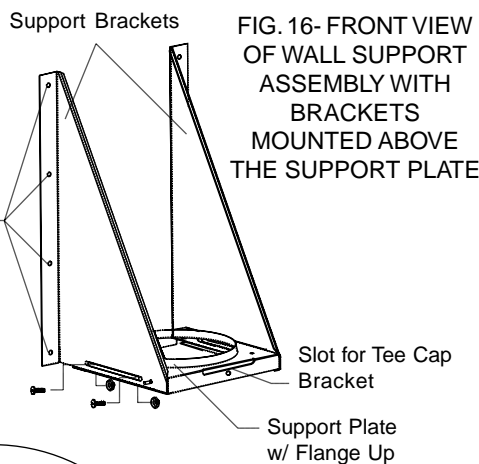

**FIG. 16- FRONT VIEW OF WALL SUPPORT ASSEMBLY WITH BRACKETS MOUNTED ABOVE THE SUPPORT PLATE**

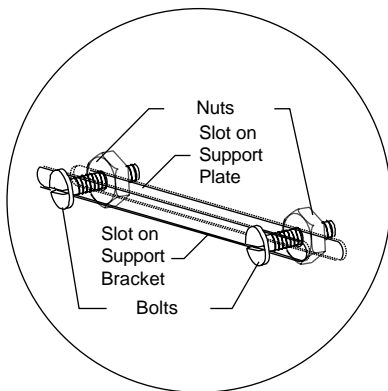

**FIG. 17- SLOT AREAS WITH BOLTS (#8 x 3/4\") AND NUTS ASSEMBLY OF SUPPORT BRACKETS AND SUPPORT PLATE**

The Cathedral Ceiling Support will support a total of 18 ft. (5.5m), of chimney sections. Chimney joints made below the support must be secured with locking bands.

After framing in your opening to the dimensions specified in the Framing Dimension Table 1, slide the Cathedral Support box into the joist/rafter opening. Once the box is at the desired level, ensure the box is level and nail the box to the framing using four 2" spiral nails or # 8 x 1-1/2" wood screws per side. The excess material sticking above the roof can either be trimmed off before attaching the box to the framing or, after it is installed the corners can be cut and the excess material folded down onto the roof deck.

Install the support band on the chimney length at the desired position by tightening the support band bolt and by screwing four stainless steel sheet metal screws through the support band and into the outer casing. NOTE: A minimum of 1" of the insulated chimney length must protrude below the Cathedral Support Box for stability (see Chart 3 in these instructions for more details). Do not over-tighten so that the band deflects the chimney outer casing. Lower the chimney length down through the opening in the bottom of the support so that the Support Band makes contact with the bottom of the Support Box (see Figure 19).

**NOTE:** The male end (coupler) of each chimney length must be pointing upwards as per the arrow on the chimney label.

### Cathedral Ceiling Support Installation

The bottom chimney length(s) should protrude into the living space so that proper clearances are maintained from the flue pipe connector to the lower side of the ceiling (see Chart 3 in these instructions for more details). Do not offset the JM/ALT chimney below the Cathedral Ceiling Support. Lengths below the support can be painted with a high temperature heat resistant paint to match the connector pipe. Follow the paint manufacturer's instructions.

**NOTE:** To reduce cold air infiltration into the dwelling you can install the optional Universal Shielding Insulation (JUSI) into the Cathedral Ceiling Support. See separate installation instructions packaged with the JUSI.

**FIGURE 19**

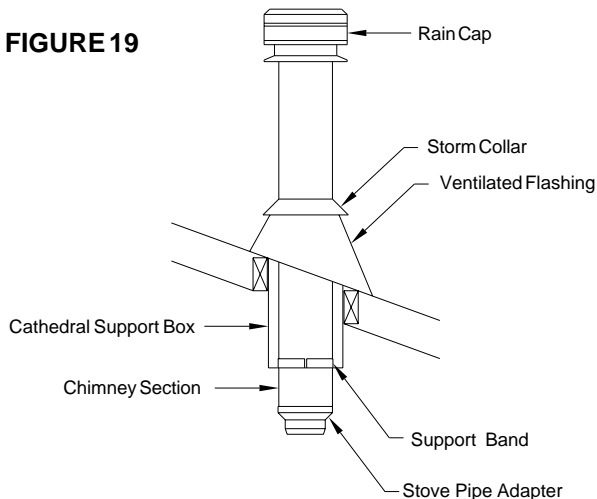

Install additional chimney sections and lock together by turning clockwise until the two sections lock together tightly. Continue in this manner until the required height above the roof is achieved. Chimney sections installed below the Cathedral Ceiling Support are locked together from below with each joint being secured by a Locking Band. A Roof Guy Kit may be required if the chimney extends 5 ft (1.5m) or more above the roof line. NOTE: Unlike normal inside installation, a Cathedral installation provides only one support point which may allow the chimney to sway slightly or vibrate in high winds. It is advisable to install additional lateral support.

4 painted ceiling trim angles (2 short & 2 long) are supplied with fastening screws to finish off the Support Box at the ceiling level. The 2 long pieces are trimmed off to match the pitch of the ceiling.

## ROOF SUPPORT

The Roof Support may be used on a floor, ceiling or roof and adjusts to any roof pitch. It may be used above an offset to support the chimney or as a supplementary support when the chimney height exceeds that of the primary support. It will also provide additional support for a Cathedral Ceiling installation when more than 3 feet is above the roof. The Roof Support will support a total height of 39 ft. (11.9m) chimney sections. All chimney sections below the support must be secured with locking bands.

The Roof Support is mounted directly on the roof sheathing with its feet (support brackets) resting over rafters or a framed opening to form a solid base. Frame a rectangular roof opening to provide a 2" minimum air space clearance to combustible materials. The framing dimension is measured in the horizontal plane.

Attach the support brackets to the support band with the 1/2" nuts, bolts and lock washers. The lock washer is placed between the band

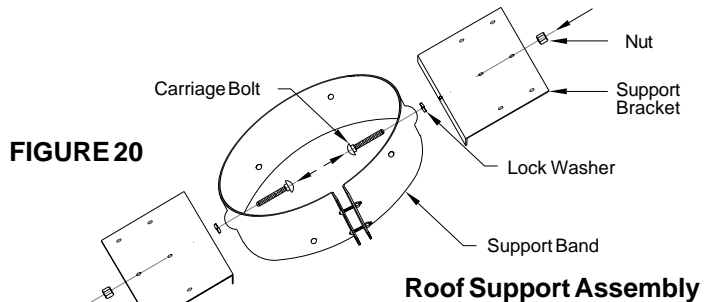

**FIGURE 20**

and support bracket to provide proper spacing as shown in Figure 20.

Slide the Roof Support down over the chimney section until its brackets rest on the roof or floor. Tighten the collar around the chimney with the nuts and bolts supplied, then secure the collar by screwing the 6 supplied metal screws through the holes in the collar and into the chimney.

Center the chimney in the joist opening (ensure that the 2" required air space clearance are met) and nail or screw the support to the roof or floor using the 12 x 3-1/2" spiral nails supplied or 12 x #8 x 1-1/4 wood screws into a solid base.

Install additional chimney sections and lock together by turning clockwise until the two sections lock together tightly - continue in this manner until the desired height is achieved. The use of Locking Bands on all Chimney Lengths above the roof is highly recommended for added safety and stability when exposed to windy conditions.

**NOTE:** The male end (coupler) of each chimney length must point up.

## RAFTER RADIATION SHIELD

A Rafter Radiation Shield must be installed where the chimney is enclosed immediately below the roof line as shown in Figures 6 & 24. An example of this is when the attic space of a house is being used as living space (ie. bedroom, guestroom etc.). It must also be installed when height restrictions will not allow the use of the Attic

**Rafter Radiation Shield**

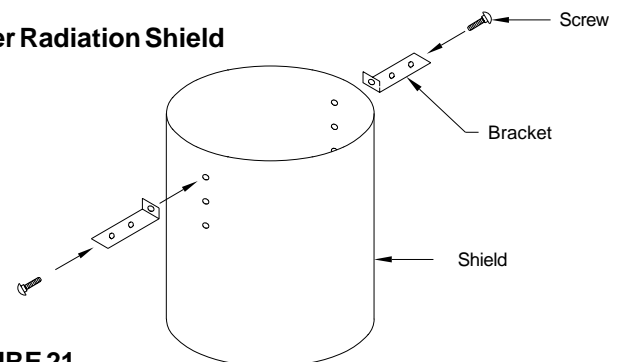

**FIGURE 21**

Insulation Shield (AIS) and the chimney has been enclosed with an enclosure around the chimney.

Attach the support brackets to the shield (through one of the three pre-punched holes) such that once the shield is installed, the shield protects both the upper and lower parts of the roof joist framing (see Figures 21 & 24).

## ROOF FLASHING

Ensure that you have the proper roof flashing by checking your roof pitch using a level and two rulers (see fig. 22) or by using a roof pitch card.

The AAF flashing is for roof pitches from flat to 6/12.

The AF2 flashing is for roof pitches from 6/12 to 12/12.

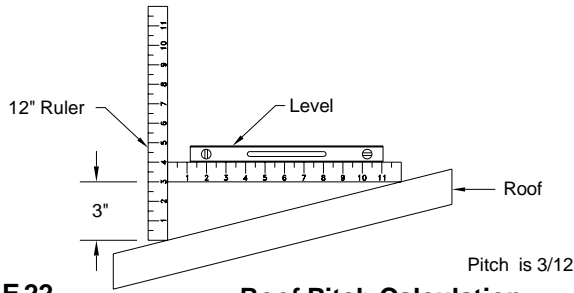

**FIGURE 22** Roof Pitch Calculation

Find the centre of the opening by dropping a plumb bob from the inside of the roof sheathing to the centre of the leveled chimney length below. Do the same to find the outline of the required opening to the edge of the hole in the ceiling below. By moving the plumb bob around the edge of the opening below (which includes the required clearance) mark several points forming the outline of the hole on the underside of the roof sheathing. Remember: these measurements are in the horizontal plane. Drill pilot holes following the marked outline.

Once you have marked and located the area where the chimney will come through the roof, center, position and prepare the roof area by removing shingles, shingle nails and cutting roofing material. Be careful when lifting roof shingles so they do not become damaged as they may be old or when the installation is done during cold weather. Frame the opening to suit the pitch of the roof and allowing for a 2" clearance to the chimney on all four (4) sides. This is done before extending the chimney above the roof.

**NOTE:** Slide the top edge (nearest the roof peak) of the flashing under the roofing shingles. At least half of the flashing should be UNDER the shingles and the bottom edge OVER the shingles to provide a watershed. Trimming off the shingles may be necessary around the cone of the flashing for a better fit. Do not nail the flashing to the roof yet as adjustments may be required.

Assemble Chimney Sections through the roof opening and Flashing. Ensure that all sections are locked together by turning clockwise until the sections lock snugly. Install Locking Bands to secure the chimney sections. Before committing to a final position of the Flashing and chimney, ensure the entire Chimney system is level and plumb and the required 2" air space clearance is maintained from all combustible material before permanently nailing and sealing of the Flashing to the roof.

Nail the flashing to the roof deck (also under the shingles) along the upper edge and down each side with 12 nails with neoprene washers or cover the nails with a suitable non hardening waterproof caulking. Seal the shingles to the plate in the same manner. As a precaution, you may apply a bead of caulking along all seams of the flashing. Wrap the Storm Collar around the chimney above the flashing. Secure

the ends together loosely with the nut and bolt supplied. Apply a non-hardening high temperature silicone caulking just above the top of the flashing cone on the chimney outer shell. Slide the collar down the chimney until it contacts the flashing cone and into the caulking. Tighten the nut and bolt and apply additional caulking above the Storm Collar as required. After the installation check to ensure that the ventilation slots are not obstructed (see Figure 23).

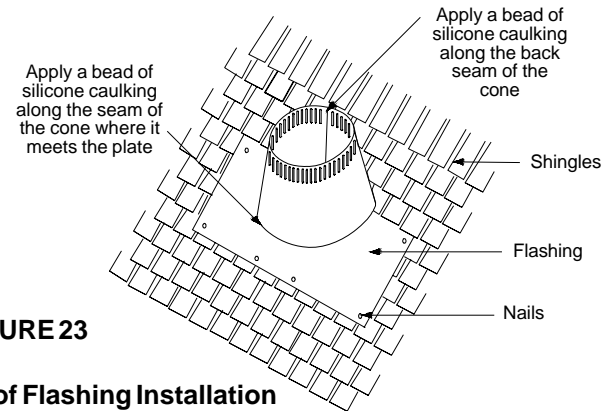

**FIGURE 23** Roof Flashing Installation

**NOTE:** A Rubber Boot Flashing Kit (URBFK2) is available as an option for passing through a corrugated or metal roof. See separate instructions packaged with the Rubber Boot Flashing Kit. On metal or steep roofs, it is recommended that an ice deflector or chimney cricket fabricated from heavy gauge galvanized steel be installed. The wedge-shaped deflector is installed 2" from the chimney on the upper slope. Its function is to split ice and snow as they slide down the roof, preventing damage to the chimney and flashing. Contact your dealer or a sheet metal fabrication shop in your area for your custom ice deflector. This also should be painted with a suitable metal paint by following the paint manufacturer's instructions.

The flashing and storm collar may be painted to match the roof shingles. This will extend its life and improve the appearance. The chimney may also be painted with a HEAT RESISTANT paint. To improve adhesion to the chimney, degrease, clean and prime before painting. Follow the paint manufacturer's instructions.

Continue adding chimney lengths until the proper height is achieved (see Figure 1). Install locking bands at all chimney joints above the roof for added protection. Install the rain cap and lock it in place by turning clockwise until tight.

**WARNING: DONOT BLOCK THE VENTILATION SLOTS ON THE FLASHING.**

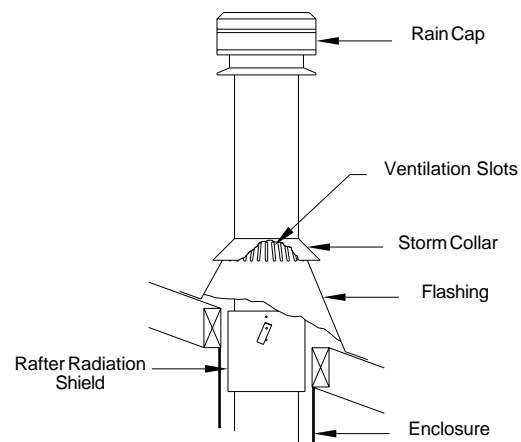

**FIGURE 24** Storm Collar/Flashing Installation

## UNIVERSAL ROOF GUY KIT

If the chimney extends 5 ft. (1600 mm) or more above the roof deck, roof guys are required. The Roof Guy Kit containing telescopic legs and draw band are suitable for this application. The draw band must be clamped around the chimney. Use suitable fasteners such as #10 or #12 x 2" wood screws to secure the legs to the roof. Make sure the fasteners are into the rafters and not just the roof sheathing.

Position the band approximately two thirds of the way up the chimney height. The preferred location for the band is next to a joint, immediately above or below a locking band. The two telescopic legs should form an angle of about 60 degrees to give support to the chimney in all directions. Keep bottom ends equal distance from the chimney and if possible, at the same elevation, on the high side of the sloped roof.

Seal the roof with a suitable non-hardening waterproof caulking. After the legs are attached to the chimney and bands, tighten the clamps on the legs to fix the position of the telescoping legs (see Figures 25 through 29). Only one chimney joint should be above a Roof Guy, the addition of a secondary Roof Guy may be required.

NOTE: Do periodic inspection of all fasteners including the clamps as high winds can cause the chimney system above the roof to vibrate and in time loosen some of the fasteners.

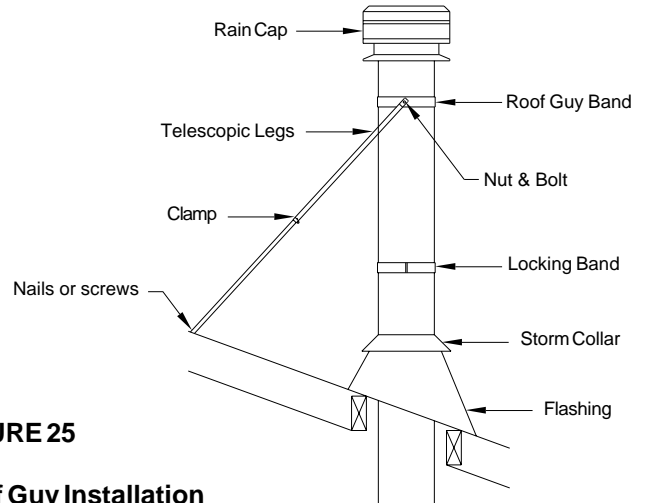

**FIGURE 25**  
**Roof Guy Installation**

## UNIVERSAL ROOF GUY BAND (JURGK) ASSEMBLY INSTRUCTIONS

1. Measure the **outside** diameter of your chimney.
2. Mark the hole at each end of the band that corresponds to the diameter measured. These 2 holes along with the "Common" hole will be utilized for your particular chimney.

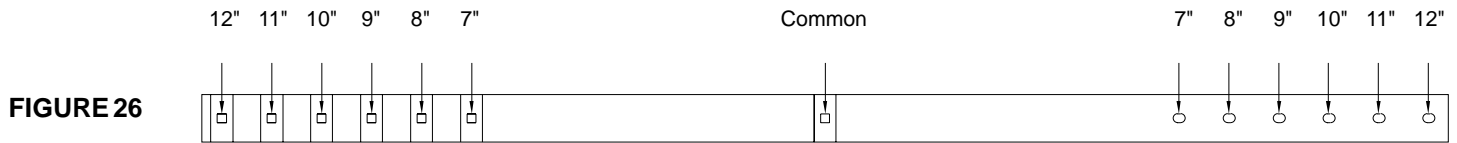

**FIGURE 26**

3. On the "Common" hole assemble 1 carriage bolt, 1 5/16" lock washer, 1 bracket, 1 1/4" lock washer and 1 1/4" hex nut in place as shown. Do not tighten the nut in place at this time

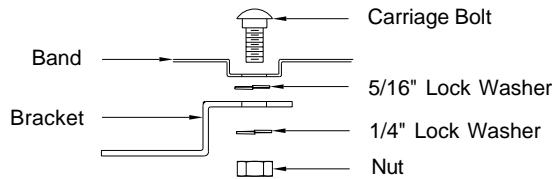

**FIGURE 27**

4. Install the band onto the chimney by placing the second carriage bolt through the correct size **square** hole, wrap the band around the chimney, and place the corresponding oval hole over the carriage bolt, and continue to assemble the remaining hardware as shown above. (On smaller diameter chimney the excess band material should be cut off)
5. Assemble roof guy legs by sliding supplied clamp over larger diameter leg and then inserting smaller diameter leg into larger diameter leg.
6. Temporarily hold legs together by tightening clamp over cut section of larger diameter leg.

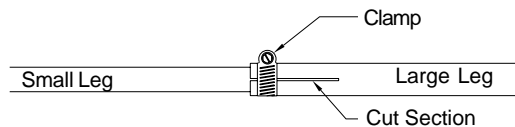

**FIGURE 28**

7. Attach the Roof Guy Legs (**non-bent end**) to the 2 brackets on the band using the 1" slot head screws, 1/4" lockwashers and 1/4" hex nuts.

8. Loosen off roof guy legs, and extend them until they come in contact with the roof surface, and nail in place.
9. Re-tighten clamps on legs, tighten the band and brackets in place, and then tighten the legs to the band.

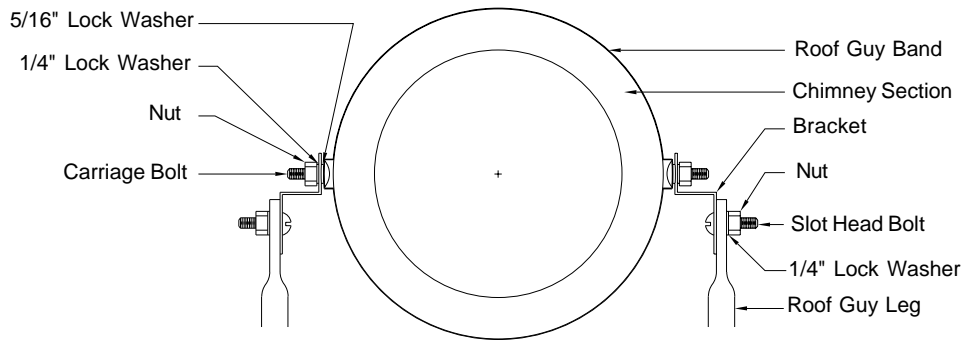

**FIGURE 29**

## **MASONRY ADAPTER KIT**

The Masonry Adapter Kit is intended for use in replacing part of a damaged existing masonry chimney with model JM/ALT chimney. It could also be used for adapting "listed" factory-built fireplaces to model JM/ALT chimney. Follow the installation instructions accompanying the factory-built fireplace.

In order to adapt an existing masonry chimney to the model JM/ALT chimney, the following parts are required:

- Masonry Adapter Kit (MAK): The kit includes a Masonry Adaptor Plate, Masonry Adapter Flashing and Storm Collar
- Suitable lengths of chimney
- Rain Cap: Standard or Deluxe model.

Depending on the installation, other parts that may be required are:

- Wall Band(s)
- Roof Flashing Assembly
- Roof Guy Kit
- Finishing Plate

To replace part of an existing masonry chimney that may be damaged, the damaged part must first be removed so that both the clay liner and the brick exterior are flush with one and other. If the clay liner is damaged further down than the brick exterior, it is recommended that you line the clay tile with a chimney liner (VERSA-LINER™ Stainless Steel Liner by Selkirk) that is listed for existing masonry chimneys, or continue removing the chimney until both the clay tile and exterior are in good condition.

Once the damaged portion of the chimney has been removed, add a bead of refractory cement to the clay tile, center the Masonry Adapter Plate on the existing masonry chimney and attach it to the masonry by drilling eight (8) 3/16" x 2" holes and inserting suitable anchor shields. Bolt in place using the 8 supplied self tapping anchor screws.

**NOTE:** Ensure the anchors are placed in the refractory and not in the mortar by utilizing the extra holes supplied in the plate. Once complete there should be one anchor in each corner as well as one anchor midway between each corner.

Install the appropriate chimney section(s) on to the Masonry Adaptor Plate and lock the chimney section(s) into place (see Figure 30). Slide the Masonry Adaptor Flashing down over the installed chimney until it comes in contact with the Adapter Plate. Notch the 4 corners of the plate as shown in Figure 31.

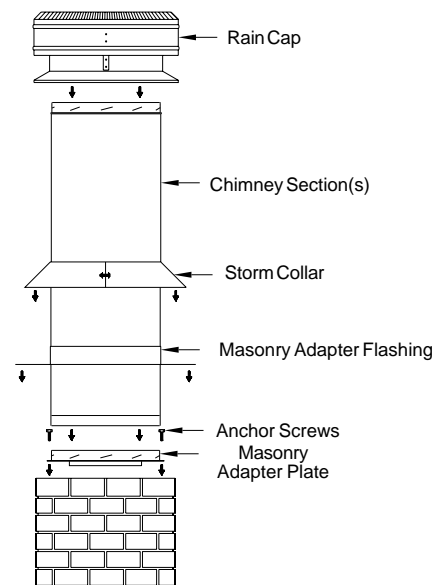

**FIGURE 30 Masonry Adapter Installation**

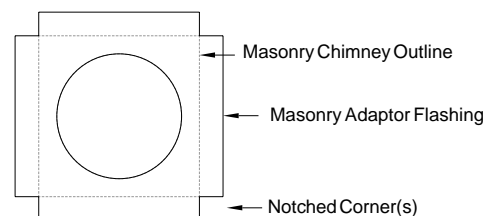

**FIGURE 31 Masonry Adapter Flashing Installation**

Bend the four edges of the flashing around the masonry chimney so the flashing fits tight to the masonry. Wrap the Storm Collar around the chimney above the flashing. Secure the ends together loosely with the nut and bolt supplied. Slide the collar down the chimney until it contacts the flashing. Tighten the nut and bolt and seal the Storm Collar to the chimney with a suitable waterproof non-hardening high temperature silicone caulking.

The flashing and storm collar can or may be painted to match the masonry brick. This will extend its life and improve the appearance. Clean, prime and paint with suitable painting product and follow the paint manufacturer's instructions.

Continue adding chimney lengths until the proper height is achieved (see Figure 1). Install a rain cap (Standard or Deluxe model) and lock it in place by turning clockwise until tight.

If there is 5 ft. (1600 mm) or more of chimney installed on the adapter plate, roof guys are required above the roof line (see Roof Guy Kit section).

If the chimney is being replaced below the soffit, additional lateral support must be provided by the use of wall bands at 8 ft. intervals (see Wall Support section in these instructions).

## **ADAPTER PLATE**

It is of the utmost importance that the Adapter Plate be installed in accordance with the "Listed" factory-built fireplace manufacturers installation instructions.

Ensure that you obtain any necessary building permits and that your installation will conform with all federal, provincial, municipal installations and fire codes for all requirements affecting your installation.

## **Maintenance And Chimney Cleaning:**

### **“Creosote and Soot - Formation and Need for Removal”**

The need for chimney maintenance depends on the kind of appliance and how it is operated. Gas and oil-burning appliances need very little, but wood burning appliances may need a great deal of chimney maintenance.

How you burn wood in your stove, fireplace or any other solid fuel appliance directly affects the formation of creosote. Good operating and firing techniques of your wood appliance will have a positive impact in reducing creosote build-up. Burn hot, bright fires and fire each load hot. It is important to load your appliance properly and to avoid smoldering fires. By doing so, it reduces creosote formation and the risk of chimney fires. Fast, effective start-ups are important, but also the moisture content of the wood being burned. If your wood is not thoroughly seasoned, split your wood in smaller pieces instead of larger ones. Ideally, the moisture content of your firewood should be between 18 and 22 percent. To assist you in using your wood burner more effectively is in monitoring your system with a surface thermometer for single wall stove pipe or a probe thermometer for double wall stove pipe. Follow the manufacturers instructions packaged with the thermometer.

Burn only low sulphur content coal (1% or less) such as anthracite. Burn only dry-shelled corn at 14-15% or less. Ensure that the chimney system is not oversized for the appliance it serves. Check with the appliance manufacturers for the proper sizing of the chimney.

When wood is burned slowly, it produces tar and other organic vapors, which combine with expelled moisture to form creosote. The creosote vapors condense in the relatively cool chimney flue of a slow-burning fire. As a result, creosote residue accumulates on the flue lining. When ignited, this creosote creates a chimney fire with extremely high temperatures.

With a new installation, the chimney should be inspected frequently (every 2 wks) to determine the rate of creosote formation. When familiar with the appliance and chimney characteristics, the chimney should be inspected at least once every 2 months during the heating season to determine if a creosote or soot build-up has occurred. Check spark arrester screens at least every 2 to 4 weeks. If the spark arrester becomes clogged with creosote, it should be cleaned or replaced.

If creosote or soot has accumulated, it should be removed to reduce the risk of a chimney fire. Depending on the rate of build-up (as little as 1/16") and as you learn what is going on in the chimney, you can adjust your cleaning schedule accordingly. Every chimney flue and flue pipe shall be inspected annually and cleaned as often as may be necessary to keep the chimney and flue pipe free from dangerous accumulation of combustible deposits.

Chimney and flue pipe are particularly susceptible to off-season condensation. The incomplete combustion of wood produces acids which, when combined with moisture, are corrosive. During the heating season, corrosion tends not to occur because the heat in the system evaporates the condensation of any water vapour that may be formed.

Warm, moist air during the summer months passes slowly through the heating system. It makes any remaining ash or creosote moist and soggy. Corrosion of steel occurs where these deposits remain.

Off-season corrosion can be reduced considerably if the system is thoroughly cleaned after the last fire of the heating season. Where coal or shelled corn is burned, the system must be thoroughly cleaned within 48 hours of shutting down the system for the season and all soot be removed from the chimney system. This should be the most important cleaning the system receives all year. Air inlets should be closed and sealed if necessary to prevent the constant flow of air through the system.

#### **WARNING:**

**DONOTUSEFUELMATERIALSCORROSIVETO THE CHIMNEYLINERSUCHASDRIFTWOOD, PLASTICS, CHEMICALLYTREATEDWOOD,ETC.**

Contact a professional certified chimney sweep for chimney cleaning services and advice if you have any doubt about your ability to clean your chimney system or if the task is too large. To visually inspect the chimney, remove the Rain Cap by simply using the twist-lock feature. Care should be taken not to disengage any lower chimney sections. By removing the Rain Cap this will permit the insertion of a properly sized plastic chimney cleaning brush. A metal brush may scratch the liner and lead to premature corrosion. The Tee Plug can be removed by removing the the securing screw and sliding the Tee Cap Bracket out. Be sure to replace the Rain Cap and the Tee Plug with Tee Cap Bracket and securing screw once you have completed inspecting and cleaning the chimney.

If chemical cleaner is used to assist in the cleaning of your chimney, make sure it is a product which is non corrosive. It does not replace the need for a mechanical cleaning. The optimal method for cleaning a chimney is by a mechanical brushing of the chimney in conjunction with a complete evaluation of the system by a certified chimney sweep.

### **CHIMNEY FIRES AND WHAT TO DO ABOUT THEM:**

Your Model JM/ALT chimney is not intended or designed for use as a combustion or fire chamber. It is very easy to overfire your woodburning appliance with kindling, scrap lumber, brush or any fast burning fuel. This can produce flames and high temperatures all the way up the chimney, and may cause appliance and chimney damage.

If you see your appliance or the flue pipe glowing red, you are risking chimney damage or a fire. The creosote may be burning inside the chimney. If you see flames coming out at the top, you are either overfiring or there is a chimney fire.

If the fire in your appliance has gotten out of control, or if you suspect a chimney fire for any reason, follow these steps:

1. Immediately close all dampers and/or air entrance openings to your appliance. Block off fireplace openings.

2. Alert your family to the possible danger.

3. Inspect your appliance and chimney surroundings for possible fire. If in doubt, alert your Fire Department.

4. Do not continue to operate your appliance until it and your chimney have been thoroughly inspected. Overheating can cause metal parts to expand, buckle and crack. If you are not certain, have a certified wood technician or certified chimney sweep disassemble all parts so they can be inspected and replaced.

5. Do not use salt or water on the fire in your appliance. Salt is corrosive and water will cause a dangerous steam explosion. You might be able to control the fire by using ashes, sand or baking soda. Baking soda is an ingredient used for dry chemical fire extinguishers.

6. After a chimney fire, when it is safe to do so, check internal locations such as the attic and under the roof and keep watching for two or three hours. There may be delayed smoldering and subsequent ignition, even if the fire inside the chimney has been controlled.

### **REPLACEMENT PARTS LIST**

<b>DESCRIPTION</b>	<b>SUPERPRO 2100 PART NO.</b>	<b>SUPERVENT 2100 PART NO.</b>
36" Chimney Length	ALT*36	JM*S36
24" Chimney Length	ALT*24	JM*S24
18" Chimney Length	ALT*18	JM*S18
12" Chimney Length	ALT*12	JM*S12
6" Chimney Length	ALT*06	JM*S6
Tee with Insulated Plug	ALT*TEE	JM*TEE
15° Elbow Kit	ALT*E15K	JM*SEK
30° Elbow Kit	ALT*E30K	JM*SE3K
Decorator Ceiling Support	ALT*CS-1	JM*DCS-1
Wall Support	JM*WS	JM*WS
Cathedral Ceiling Support	ALT*CB	JM*CCSB
Roof Support	JM*RS	JM*RS
Locking Band	ALT*SLB	JM*SLB
Stove Pipe Adapter	JM*ASE	JM*ASE
Wall Thimble	ALT*AT	JM*WT
Wall Band	JM*WB	JM*WB
Universal Roof Guy Kit	JURGK-1	JURGK-1
Adapter Plate	JM*AP	JM*AP
Attic Insulation Shield	JM*AIS	JM*AIS
Rafter Radiation Shield	JM*RRS	JM*RRS
Finishing Plate	JM*FP	JM*FP
Deluxe Rain Cap	ALT*PRC	JM*DRC
Flat Roof Flashing	JM*ATC	JM*ATC
0/12 - 6/12 Roof Flashing	JM*AAF	JM*AAF
6/12 - 12/12 Roof Flashing	JM*AF2	JM*AF2
Storm Collar	JM*ASC-1	JM*ASC-1
Flashing Silicone Sealant	JRTV	JRTV
Rubber Boot Flashing	URBFK2	URBFK2
Universal Shielding Insulation	JUSI	JUSI

\* Specify chimney diameter

Model SuperPro 2100 (ALT) and Model SuperVent 2100 (SC-1) chimney and components are listed to CAN/ULC-S629 and both manufactured by Selkirk and as such are interchangeable with one and other.

# CHART 1 - OFFSET CHIMNEY INSTALLATION

It may be necessary to offset the chimney in order to clear a joist or an obstacle. The two (2) charts below will assist you in selecting the proper combination of elbow angle and chimney length(s) that will provide the necessary degree of offset within an available height.

1. Select the column with the proper chimney diameter of your system.

2. Determine the distance of the offset required by dropping a plumb line for an accurate measurement. The offset is measured at the chimney centre line as per the "A" Offset measurement in the diagram below.

3. On the chart, find the predetermined distance (under the "A" column) required for the 15° elbow. For greater offset, use the 30° offset chart.

4. After finding the offset, look at the "B" (height) measurement in the diagram below and under column "B" in the chart to find the specified height. The appropriate "chimney lengths" required in between elbows is found in the left hand side column on the chart..

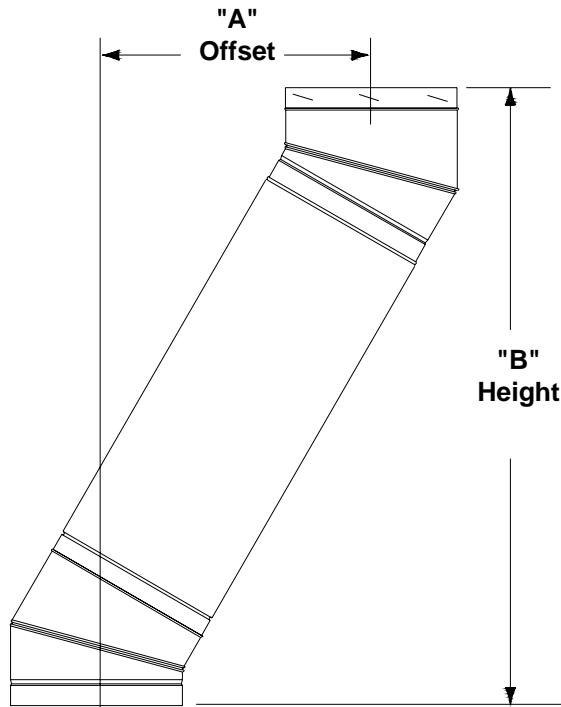

<b>15° OFFSET CHART</b>						
<b>Chimney Lengths</b>	<b>6" Diameter</b>		<b>7" Diameter</b>		<b>8" Diameter</b>	
	<b>A</b>	<b>B</b>	<b>A</b>	<b>B</b>	<b>A</b>	<b>B</b>
none	1-1/4"	10-5/8"	1-5/16"	11"	1-5/8"	11-3/8"
6"	2-1/16"	15-3/8"	2-1/4"	15-3/4"	2-1/2"	15-3/4"
12"	4-1/16"	21-1/4"	4-1/8"	21-1/2"	4-1/8"	21-13/16"
18"	5-5/8"	27-3/16"	5-11/16"	27-3/8"	5-11/16"	27-5/8"
24"	7-1/4"	33"	7-1/4"	33-1/8"	7-1/4"	33-3/8"
6"+12"+18"	8-7/16"	37-5/8"	8-7/16"	37-7/8"	8-1/2"	38-3/16"
36"	10-1/4"	44-1/2"	10-1/4"	44-3/4"	10-3/8"	45-1/16"
6"+18"+24"	11-1/2"	49-1/4"	11-9/16"	49-3/8"	11-11/16"	49-3/4"
12" + 36"	13-1/8"	55"	13-1/8"	55-1/4"	13-1/4"	55-5/8"
18" + 36"	14-11/16"	60-3/4"	14-5/8"	61-1/4"	14-3/4"	61-5/8"
24" + 36"	16-1/4"	66-3/4"	16-3/16"	66-7/8"	15-5/16"	67-1/8"
12"+24"+36"	19"	77-5/16"	19"	77-9/16"	19"	77-11/16"

<b>30° OFFSET CHART</b>						
<b>Chimney Lengths</b>	<b>6" Diameter</b>		<b>7" Diameter</b>		<b>8" Diameter</b>	
	<b>A</b>	<b>B</b>	<b>A</b>	<b>B</b>	<b>A</b>	<b>B</b>
none	3-9/16"	14-3/16"	3-3/4"	15-1/2"	3-7/8"	15-3/8"
6"	5-7/8"	18-5/16"	6-1/4"	19-1/2"	6-3/8"	19-3/4"
12"	8-7/8"	23-9/16"	9-1/4"	24-3/4"	9-3/8"	25"
18"	11-15/16"	28"	12-5/16"	29-13/16"	12-7/8"	30-1/16"
24"	14-15/16"	34-1/16"	15-5/16"	35-3/8"	15-7/16"	35-1/4"
6"+12+24"	17-5/16"	38-5/16"	17-5/8"	39-3/16"	17-9/16"	39-5/8"
36"	20-7/8"	44-9/16"	21-1/4"	45-5/8"	21-7/16"	46-1/16"
6" + 36"	23-5/16"	48-15/16"	23-11/16"	49-3/4"	23-7/8"	50-3/16"
12" + 36"	26-5/16"	54-1/8"	26-11/16"	54-15/16"	26-7/8"	55-9/16"
18" + 36"	29-5/16"	59-5/16"	29-11/16"	60-1/8"	29-9/16"	60-3/4"
24" + 36"	32-5/16"	64-3/8"	32-9/16"	64-5/8"	32-5/8"	65-1/4"
12"+24"+36"	37-13/16"	73-13/16"	38-1/8"	74-1/16"	38"	74-5/16"

All measurements are in inches. Construction tolerances ± one inch.

**NOTE:**

- Model JM/ALT chimneys are limited to offsets not exceeding 30 degrees. Combining offsets for greater angle is not permitted.
- One pair of (two) 15° or 30° elbows may be used per interior installation.
- Never install an elbow in a joist area. Chimney sections must pass vertically through framed joist areas.
- Locking bands must be use at all chimney joints of an offset.
- Elbow support will support 15 feet of chimney and the maximum length of chimney allowed between elbows is 6 feet.



## CHART 2 - CHIMNEY HEIGHT ABOVE THE ROOF

**Requirement # 1 :** The code requires that the chimney must extend at least 3 feet (900mm) above the highest point of the roof that it penetrates.

**Requirement # 2 :** It must also be 2 feet (609mm) above any roof, wall or other obstruction within a horizontal distance of 10 feet (3m).

The following Chart is to assist you in determining the minimum chimney height you will require above the roof. You may need to add to this height as nearby buildings, trees and other parts of the house roof could interfere with airflow over and around the top of the chimney and affect its performance. If you think a nearby obstacle could affect draft, you might want to install one or more additional lengths.

DISTANCE FROM PEAK	PITCH OF ROOF											
	1/12	2/12	3/12	4/12	5/12	6/12	7/12	8/12	9/12	10/12	11/12	12/12
	<b>CHIMNEY HEIGHT ABOVE ROOF (INCHES)</b>											
10 Ft	*36	44	54	64	74	84	94	104	114	124	134	144
9 Ft	*36	42	51	60	69	78	87	96	105	114	123	132
8 Ft	*36	40	48	56	64	72	80	88	96	104	112	120
7 Ft	*36	38	45	52	59	66	73	80	87	94	101	108
6 Ft	*36	36	42	48	54	60	66	72	78	84	90	96
5 Ft	*36	*36	39	44	49	54	59	64	69	74	79	84
4 Ft	*36	*36	36	40	44	48	52	56	60	64	68	72
3 Ft	*36	*36	*36	36	39	42	45	48	51	54	57	60
2 Ft	*36	*36	*36	*36	*36	36	38	40	42	44	46	48
1 Ft	*36	*36	*36	*36	*36	*36	*36	*36	*36	*36	*36	36

All measurements are in inches with the exception of "distance from the peak" being in feet.

\* Defaulted to 36" to meet requirement #1. Both requirements (#1 and #2) must be met.

- If the chimney extends more than 5 feet or more above the roof, a Universal Roof Guy Kit (JURGK-1) is required.
- It is highly recommended that any lengths above the roof should have locking bands at all joints for added safety and stability. This will eliminate the risk of sections becoming undone below the roof line when the Rain Cap is removed when inspections and cleaning of the system is being done.

## CHART 3 - Connector Pipe Clearance below Cathedral Support

1. Identify the type of connector pipe you will be installing, single wall or Selkirk's Double Wall Stove Pipe (DSP).
2. Determine the amount of the exposed Cathedral Support that will be projecting into the room as per the "X" in the diagram on the bottom left.
3. Select the pitch of your sloped ceiling from the chart below.
4. Select the measurement from the chart below where the pitch of the sloped ceiling column intersects with the exposed cathedral row selection. This will determine the measurement of insulated chimney required below the Cathedral Support as per the "Y" in the diagram on the left. The minimum of insulated chimney below the Cathedral Support is 1 inch. This minimum is required for stability of the system.

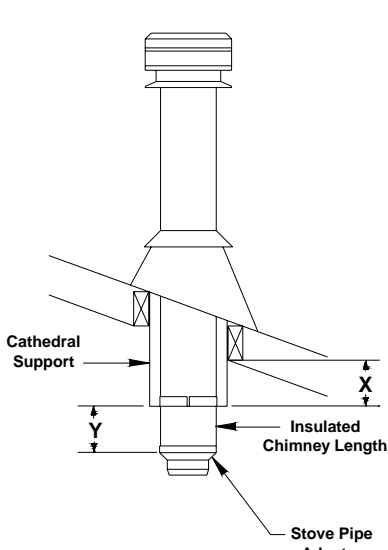

CONNECTOR PIPE CLEARANCE REQUIREMENTS FROM SLOPED CEILING													
EXPOSED CATHEDRAL SUPPORT INTO ROOM		PITCH OF SLOPED CEILING											
		1/12	2/12	3/12	4/12	5/12	6/12	7/12	8/12	9/12	10/12	11/12	12/12
1 Single Wall Flue Pipe	"X" measurement	<b>"Y" MEASUREMENT - INSULATED CHIMNEY LENGTH INTO ROOM</b>											
	Box flush to ceiling on lower end	1.5	3	4.5	6	8	9	10.5	12	13.5	15	16.5	18
	Box 1" into the room	1	2	3.5	5	7	8	9.5	11	12.5	14	15.5	17
	Box 2" into the room	1	1	2.5	4	6	7	8.5	10	11.5	13	14.5	16
	Box 3" into the room	1	1	1.5	3	5	6	7.5	9	10.5	12	13.5	15
2 DSP - Double Wall Stove Pipe	"X" measurement	<b>"Y" MEASUREMENT - INSULATED CHIMNEY LENGTH INTO ROOM</b>											
	Box flush to ceiling on lower end	1	1	1.5	2	2.5	3	3.5	4	4.5	5	5.5	6
	Box 1" into the room	1	1	1	1	1.5	2	2.5	3	3.5	4	4.5	5
	Box 2" into the room	1	1	1	1	1	1	1.5	2	2.5	3	3.5	4
	Box 3" into the room	1	1	1	1	1	1	1	1	1.5	2	2.5	3

<sup>1</sup> Single Wall Flue Pipe requires 18" clearance from any combustible materials.

<sup>2</sup> DSP Double Wall Stove Pipe requires 6" clearance from any combustible materials.

All measurements are in inches.

## INSTALLATION INFORMATION

Keep in a safe place for future reference

CHIMNEY MODEL: \_\_\_\_\_

TYPE OF APPLIANCE: \_\_\_\_\_

INSTALLATION DATE: \_\_\_\_\_

DESCRIPTION OF INSTALLATION (Chimney and Flue Pipe Configuration) \_\_\_\_\_

### ***PURCHASED FROM:***

DEALER NAME: \_\_\_\_\_

Address: \_\_\_\_\_

City: \_\_\_\_\_

Province: \_\_\_\_\_

### ***INSTALLED BY:***

TECHNICIAN NAME: \_\_\_\_\_

Address: \_\_\_\_\_

City: \_\_\_\_\_

Province: \_\_\_\_\_



## PRODUCT REGISTRATION

Please register your Chimney with the Manufacturer.

Mail to: Selkirk Canada Corporation,  
Product Registration, P.O. Box 526, Depot 1, Hamilton, ON L8L 7X6

**Register Online @: [www.selkirkcorp.com](http://www.selkirkcorp.com)**

Name: \_\_\_\_\_

Address: \_\_\_\_\_

City: \_\_\_\_\_

Province: \_\_\_\_\_ Postal Code: \_\_\_\_\_

Chimney Model: \_\_\_\_\_ Installation Date: \_\_\_\_\_

Technician Name: \_\_\_\_\_ Address: \_\_\_\_\_